

# SC/V

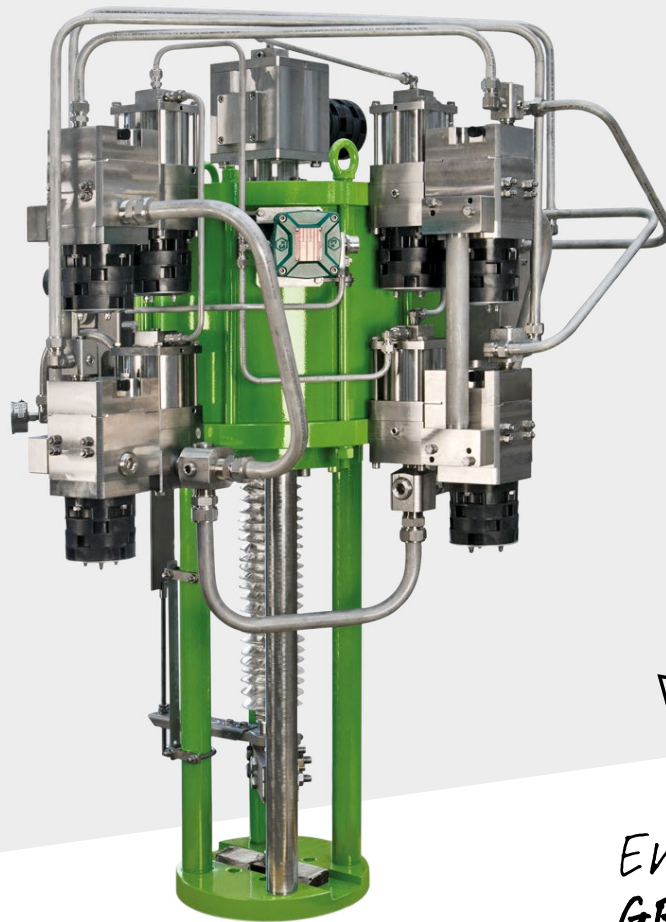

Engineering  
GREAT Solutions

## Pneumatic Valve Actuators

# SC/V: Pneumatic Valve Actuators

Our pneumatic linear piston actuators are designed to drive control valves for the most demanding applications in the power and oil & gas industries; such as turbine bypass, steam conditioning valves, desuperheaters, compressors and antisurge. Thanks to the special patented piston design, including a double ring guiding system and a grease channel providing continuous lubrication, SC/V actuators ensure smooth and precise valve operation without any maintenance for the whole operating life. This series of actuators are designed with a patented plug-in connection system for a wide range of customer-tailored accessories and control systems to meet the most demanding and critical valve operating conditions.

## Key features

- > Several sizes available from 150 mm to 1600 mm or larger if required
- > Several strokes available
- > Double acting and single or double acting plus spring design
- > Die casting aluminum bodies for small/medium sizes up to ND 320
- > Carbon steel bodies for larger sizes
- > Fully stainless steel design available for both double acting and spring return actuators for the harshest environment conditions
- > Heavy duty control actuators designed for the most challenging applications used in the oil & gas and power industries

## Benefits

- > **Capability**  
Available in single/duplex/triplex configuration for thrust and space optimization. Double acting or spring return
- > **Safety**  
SC/V actuators are designed to meet SIL 3 requirements (IEC61508) as a "single device". SIL analysis report of the safety loop available on request
- > **Flexibility**  
Manifold mounted 3 way valves and accessories for optimal performances and increased safety
- > **Built in permanent lubrication system**  
Patented piston design with double ring guiding system and grease channel which makes it virtually maintenance free
- > **Long operating life**  
Double guide for piston and bushing
- > **Protection**  
Exhaust mufflers with integral non return valve to prevent contamination of actuator internals

*Total capability in valve actuation*

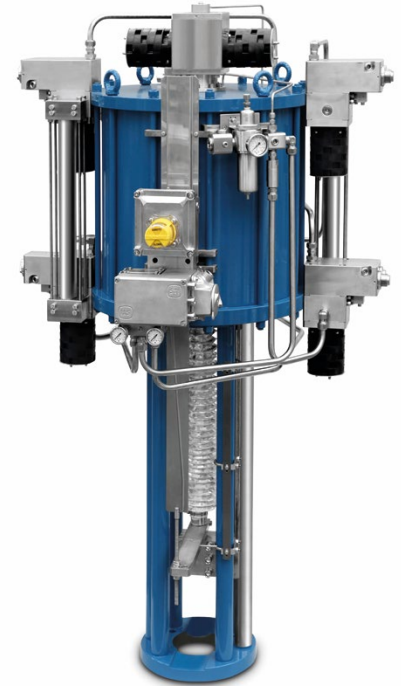

*LNG project actuator for antisurge*

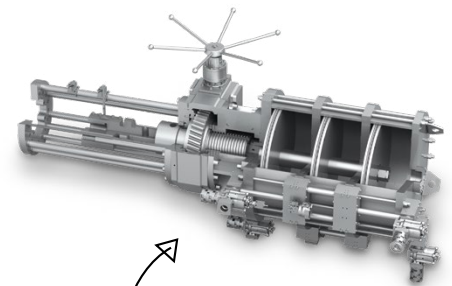

*Manifold mounted for flexibility and increased safety*

## Product specification and dimensions

### Standard pneumatic supply medium

Air, nitrogen or sweet gas (special version for sour gas on request)

### Operating pressure

Pneumatic version up to 10 bar (design up to 12 bar)

### Standard operating temperature

-20°C to 70°C (lower or higher temperature on request)

### Certifications / approvals

PED 2014/68/EU  
ATEX 2014/34/EU  
EAC TR TS 012/2011  
MACHINERY DIRECTIVE 2006/42/EC  
IP66/67M according to IEC/EN 60529  
SIL3 certified (IEC 61508)  
as a "single device"  
Designed and tested in accordance with EN 15714-3  
Further certifications are available please contact IMI STI for updated list.



Application on the North Sea

## Dimensions

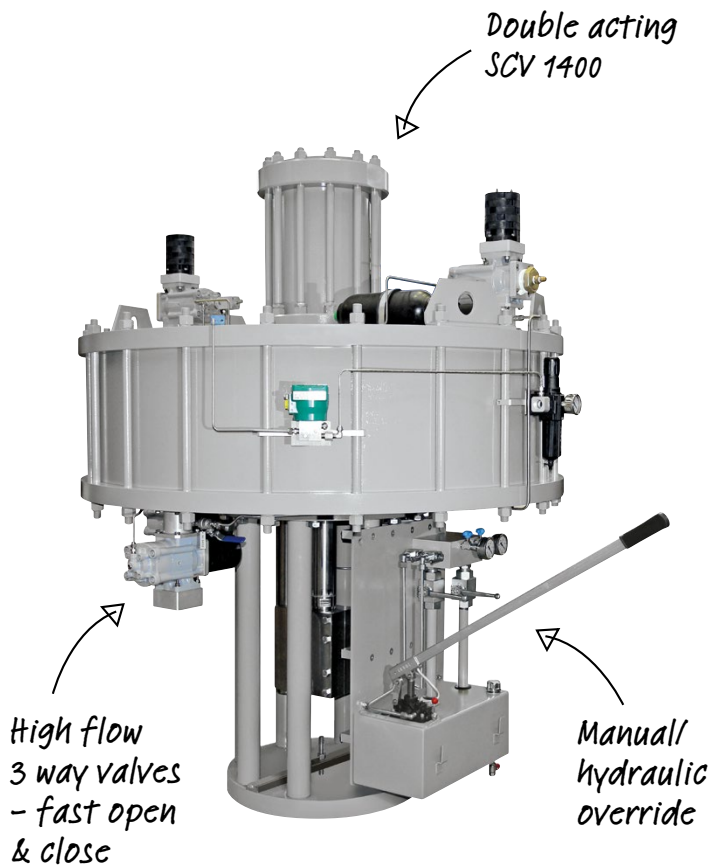

The picture shows a double acting SC/V 1400 with manual hydraulic override. High flow 3-way pneumatic valves are used to achieve very fast opening/closing time.

	1*	2	3**	4	
	SC/V actuator mm	Max. stroke mm	Active Area cm <sup>2</sup>	Thrust at 500 kPa supply daN	
Casting (Aluminum body) Size/Stroke	150/40	40	177	885	
	200/65	67	319	1595	
	200/100	103	319	1595	
	200/150	153	319	1595	
	250/80	80	497	2485	
	250/100	103	497	2485	
	250/150	153	497	2485	
	320/100	103	794	3970	
	320/200	205	794	3970	
320/300	305	794	3970		
Machined (Carbon Steel - Aluminum Alloy Stainless Steel - Composite Materials)	260/...	Available different strokes on request	521	2605	
	300/...		687	3440	
	330/...		845	4225	
	390/...		1194	5957	
	400/...		1237	6185	
	420/...		1366	6830	
	500/...		1944	9720	
	520/...		2104	10520	
	600/...		2787	13935	
	650/...		3278	16390	
	800/...		4985	24925	
	850/...		5633	28165	
	...		...	...	...
	...		...	...	...
	1600/...		20050	100250	...

Shorter travels are available on request.

\* Stroke, including reserve stroke, available for each type of actuator

\*\* This is the active area of each type of actuator

Further information and specific technical support may be obtained by contacting IMI STI sales organization.

## Optional accessories

IMI STI designs and produces a wide range of accessories and control systems to ensure superior performance and to satisfy the most demanding requirements in modulating, on/off and heavy duty service. Control systems pan-els/cabinets can be installed on the actuators or supplied loose for remote mounting which allows for easy access and limits exposure to excess heat and vibration. For more information, see dedicated brochure of accessories.

**IMI STI - Headquarters**

Via Dei Caravaggi 15  
24040 Levate (BG)  
Italy

Tel. +39 035 2928.2  
Fax +39 035 2928.247

**IMI STI - Sales Office**

Via San Francesco 18  
29017 Fiorenzuola d'Arda (PC)  
Italy

Tel. +39 035 2928.2  
Fax +39 0523 1715.295

**IMI Critical Engineering**

Lakeside, Solihull Parkway  
Birmingham Business Park  
Birmingham B37 7XZ  
United Kingdom

Tel: +44 (0)121 717 3700  
Fax: +44 (0)121 717 3701

[www.imi-critical.com](http://www.imi-critical.com)  
[imisti.sales@imi-critical.com](mailto:imisti.sales@imi-critical.com)

